



# UXC55

## ME

# Muon Endcap On Detector Layout

Prepared by Fred Borcherding  
FNAL PPD/CMS



# Naming Conventions

- Peripheral Crates, PCs, are Named  $VME+1/2$ 
  - VME(+ or – end) station(1-4)/TS 1- 6 (or 12 for ME1)
- CSCs are Named  $ME+1/2/m$ 
  - ME(+ or – end) station(1-4)/ring1, 2 or 3 sequence number m
- Dropping the + or – means the information applies symmetrically to both +Z and –Z ends
  - ME+1 AND ME-1 = ME1
- Key to Rack Names  $> X5E31$ 
  - X1 through X5 are the vertical layers
    - X2, X3 and X4 are the tower layers
    - Y coordinate
  - E, U, J, etc indicate rows in X along Z
    - +Z and –Z have different letter sets
    - X coordinate
  - 3x is on disk YE1, 4x on YE2, 5x on YE3
    - Z coordinate



# Rack Naming

- Convention for RACK Names

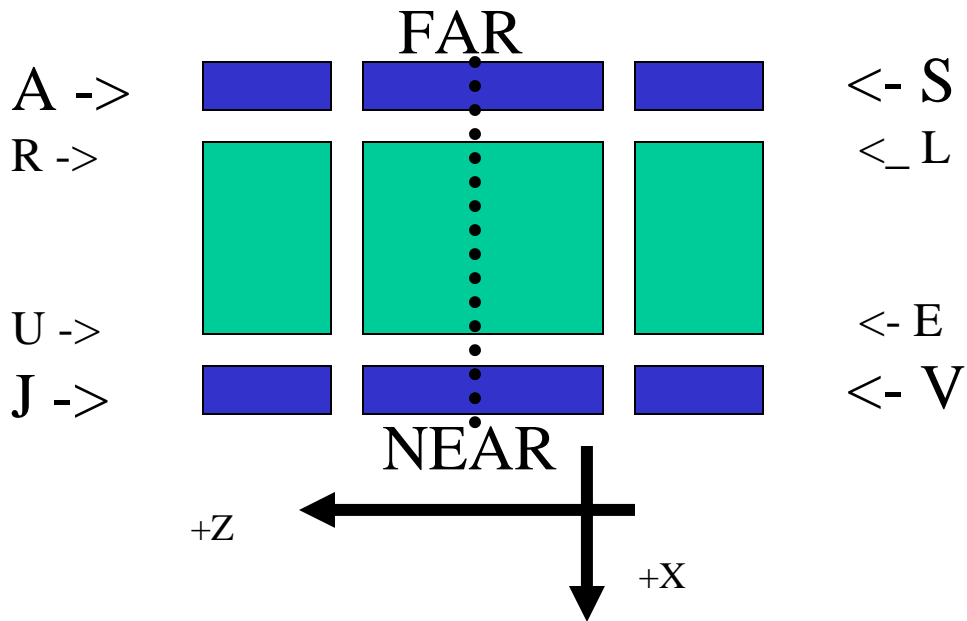
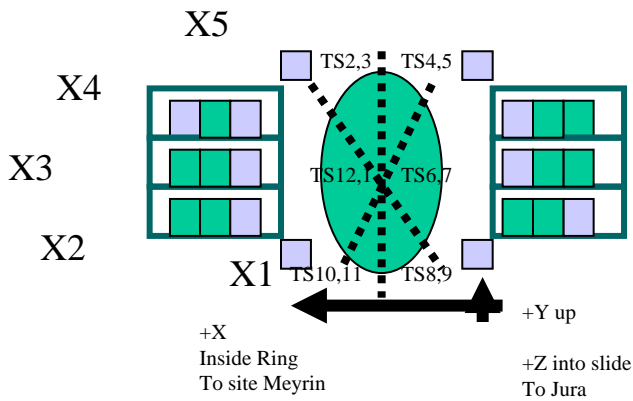



# YE+(-)1

- General layout of the YE1 End Cap disks

- are racks containing CSC hardware

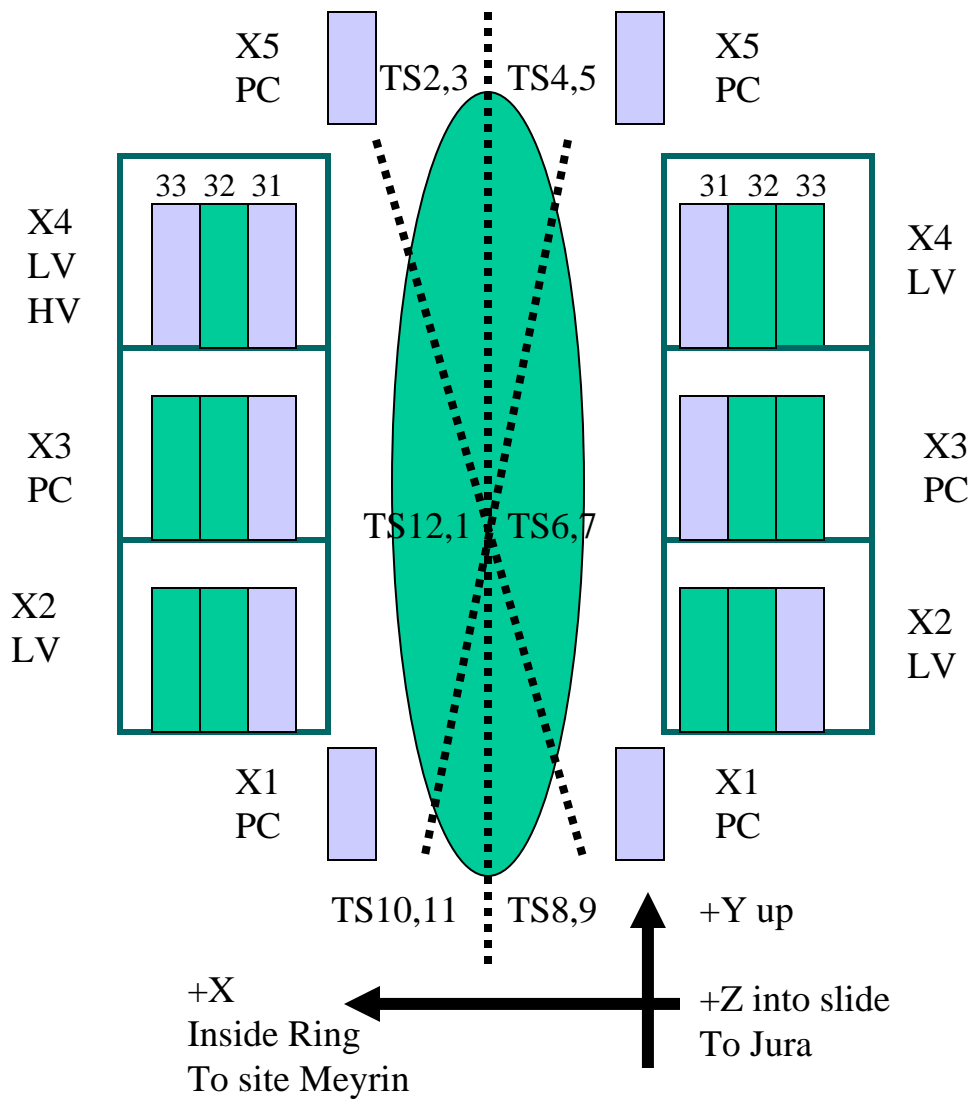



# YE+(-)2

- General layout of the YE2 End Cap disks
  - Stations ME2 and ME3

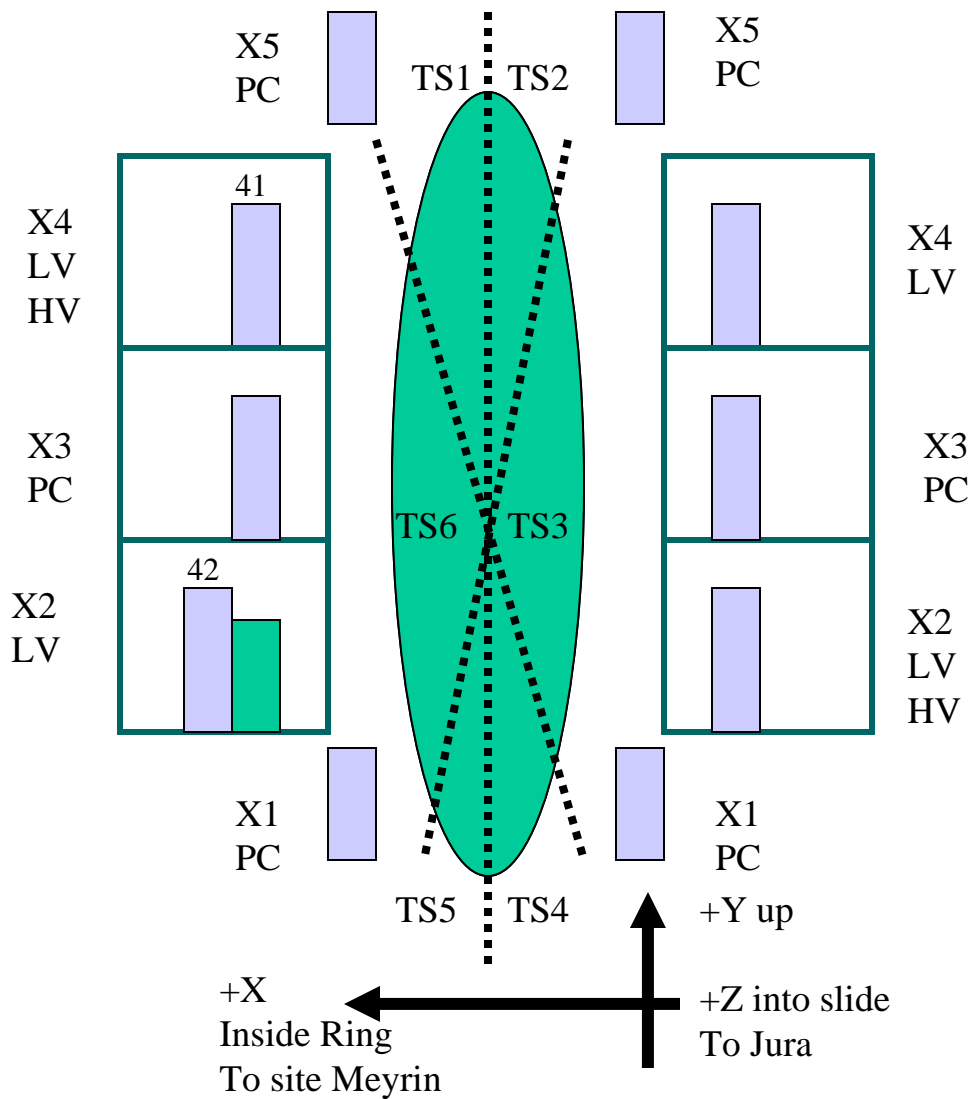



# YE+(-)3

- General layout of the YE3 End Cap disks
  - Station ME4

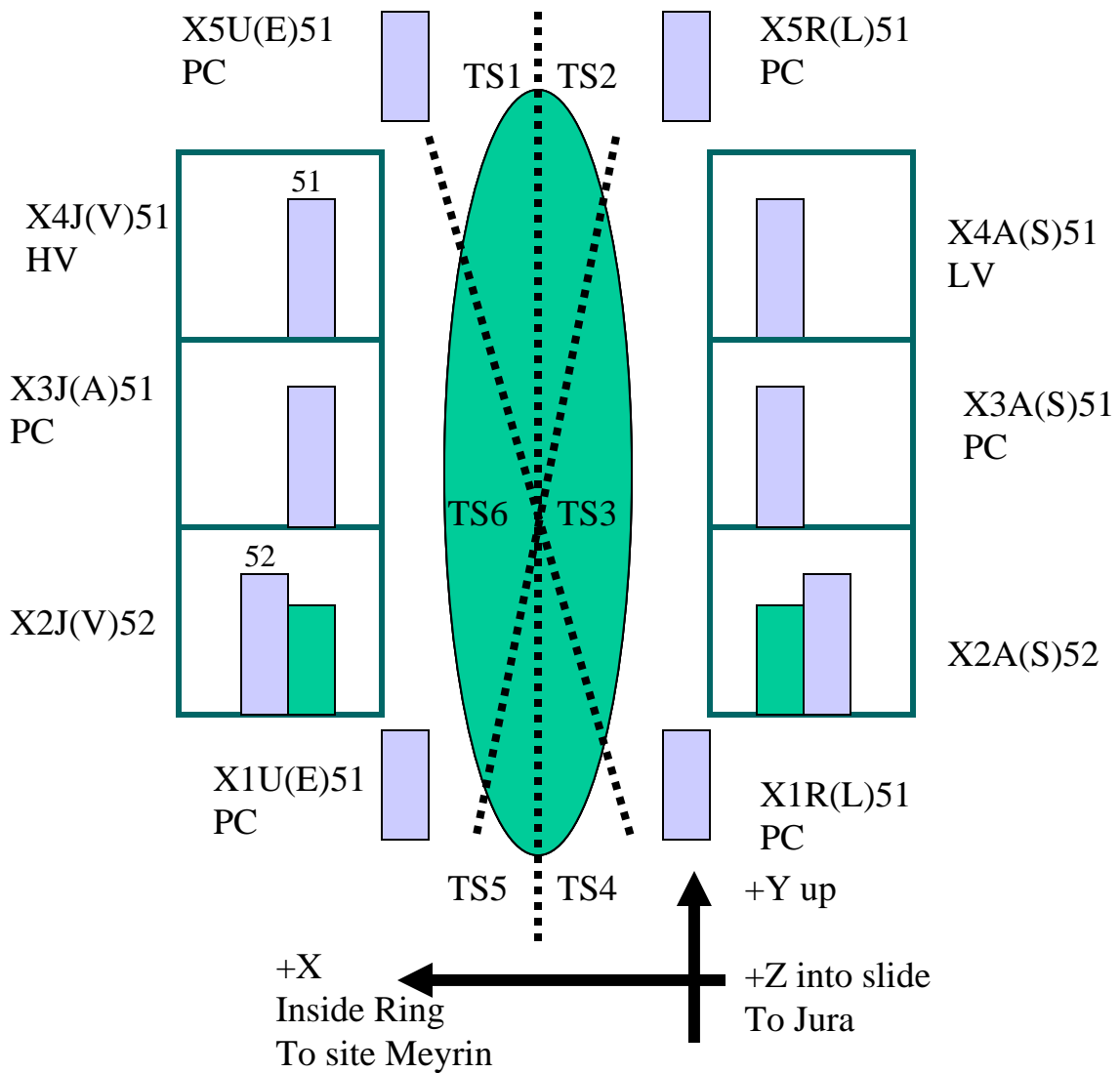



# +Z > List of Racks

- +Z and +X

- YE+1

- X5U31 – 2xPC
- X4J31 – ME LV, HE LV, Alignment
- X4J32
- X4J33 – ME HV
- X3J31 – 2xPC
- X3J32
- X3J33
- X2J31 – ME LV, ALIGNMENT
- X2J32
- X2J33
- X1U31 – 2xPC

- YE+2

- X5U41 – 2xPC
- X4J41 – ME LV, ME HV
- X3J41 – 2xPC & Alignment
- X2J42 – ME LV
- X1U41 – 2xPC

- YE+3

- X5U51 – PC
- X4J51 – ME HV & RP LBB
- X3J51 – PC, ME LV, RP LBB
- X2J52 – RP LBB
- X1U51 – PC

- +Z and -X

- YE+1

- X5R31 - 2xPC
- X4A31 – ME LV, HE LV, ??
- X4A32
- X4A33 - ME Alignment
- X3A31 – 2xPC, DSS
- X3A32
- X3A33
- X2A31 – ME LV & ALIGNMENT
- X2A32
- X2A33
- X1R31 – 2xPC

- YE+2

- X5R41 – 2xPC
- X4A41 – ME LV & ME Alignment
- X3A41 – 2xPC
- X2A41 – ME LV & ME HV
- X1R41 – 2xPC

- YE+3

- X5R51 – PC
- X4A51 – N
- X3A51 – PC, ME LV, RP LBB
- X2A52 – RP LBB
- X1R51 – PC



# -Z > List of Racks

- -Z and +X

- X5
  - X5E31 – PC
  - X5E41 – PC
  - X5E51 – PC
- X4
  - X4V31 – LV-2JB
  - X4V32
  - X4V33
  - X4V41 – LV-2JB
  - X4V51 – RPC
- X3
  - X3V31 – PC
  - X3V32
  - X3V33
  - X3V41 – PC
  - X3V51 – PC & LV-1JB
- X2
  - X2V31 – LV-4JB & ALIGNMENT
  - X2V32
  - X2V33
  - X2V42 – LV-4JB
  - X2V52 – RPC
- X1
  - X1E31 – PC
  - X1E41 – PC
  - X1E51 – PC

- -Z and -X

- X5
  - X5L31 – PC
  - X5L41 – PC
  - X5L51 – PC
- X4
  - X4S31 – LV-4JB
  - X4S32
  - X4S33
  - X4S41 – LV-4JB
  - X4S51 –
- X3
  - X3S31 – PC
  - X3S32
  - X3S33
  - X3S41 – PC
  - X3S51 – PC & LV-1JB
- X2
  - X2S31 – LV-2JB & ALIGNMENT
  - X2S32
  - X2S33
  - X2S41 – LV-2JB
  - X2S52 – RPC
- X1
  - X1L31 – PC
  - X1L41 – PC
  - X1L51 – PC

Key >> X1 through X5 are the layers, X2, X3 and X4 are the tower layers  
U, J, etc indicate row in Z

31 is on disk YE+-1, 41 on YE+-2, 51 on YE+-3





# Cable Chains

- From floor to YE1
- From YE1 to YE2
- From YE1 to YE3

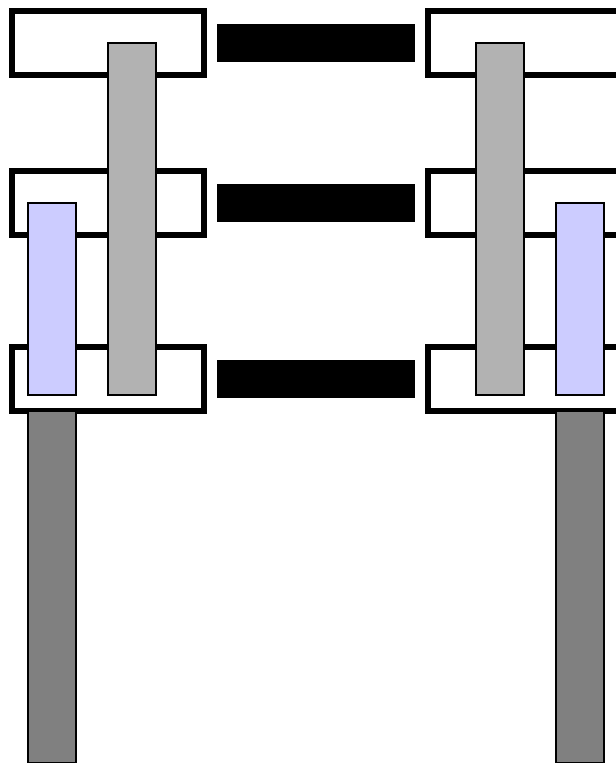



# YE+(-)1 ME LV

- Maraton in each of 4 corners
  - 2 power boxes per rack
- CSC LV Distribution Boxes shown in BROWN
  - 4 boxes and
  - 2 boxes in opposite corners
- Each rack supplies
  - 4 PCs + 2 TS of CSCs
    - or
  - 2 PCs + 4 TS of CSCs

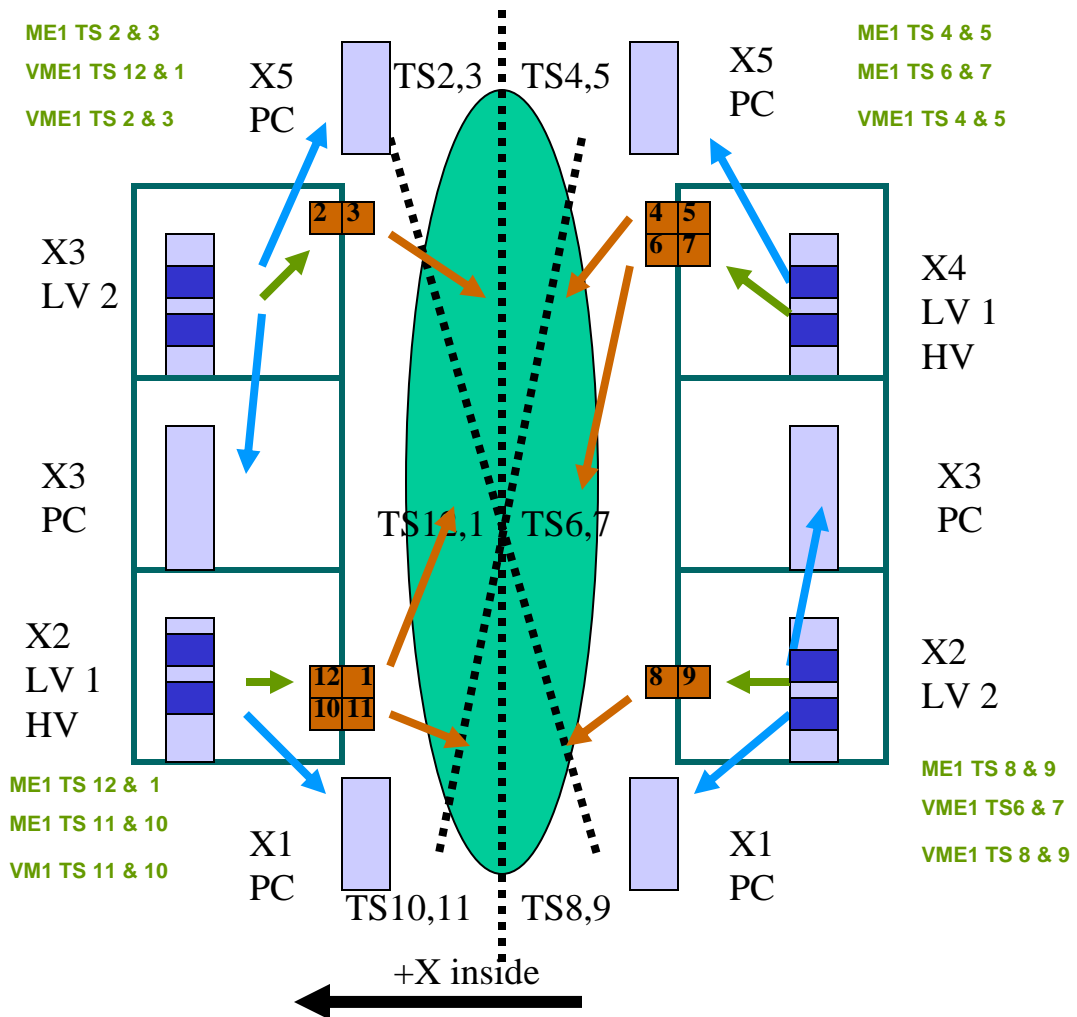



# YE+(-)2 ME LV

- Maraton in each of 4 corners
  - 2 power boxes per rack
- CSC LV Distribution Boxes shown in BROWN
  - 4 boxes and
  - 2 boxes in opposite corners
- Each rack supplies
  - 4 PCs + 2 TS of CSCs
    - or
  - 2 PCs + 4 TS of CSCs

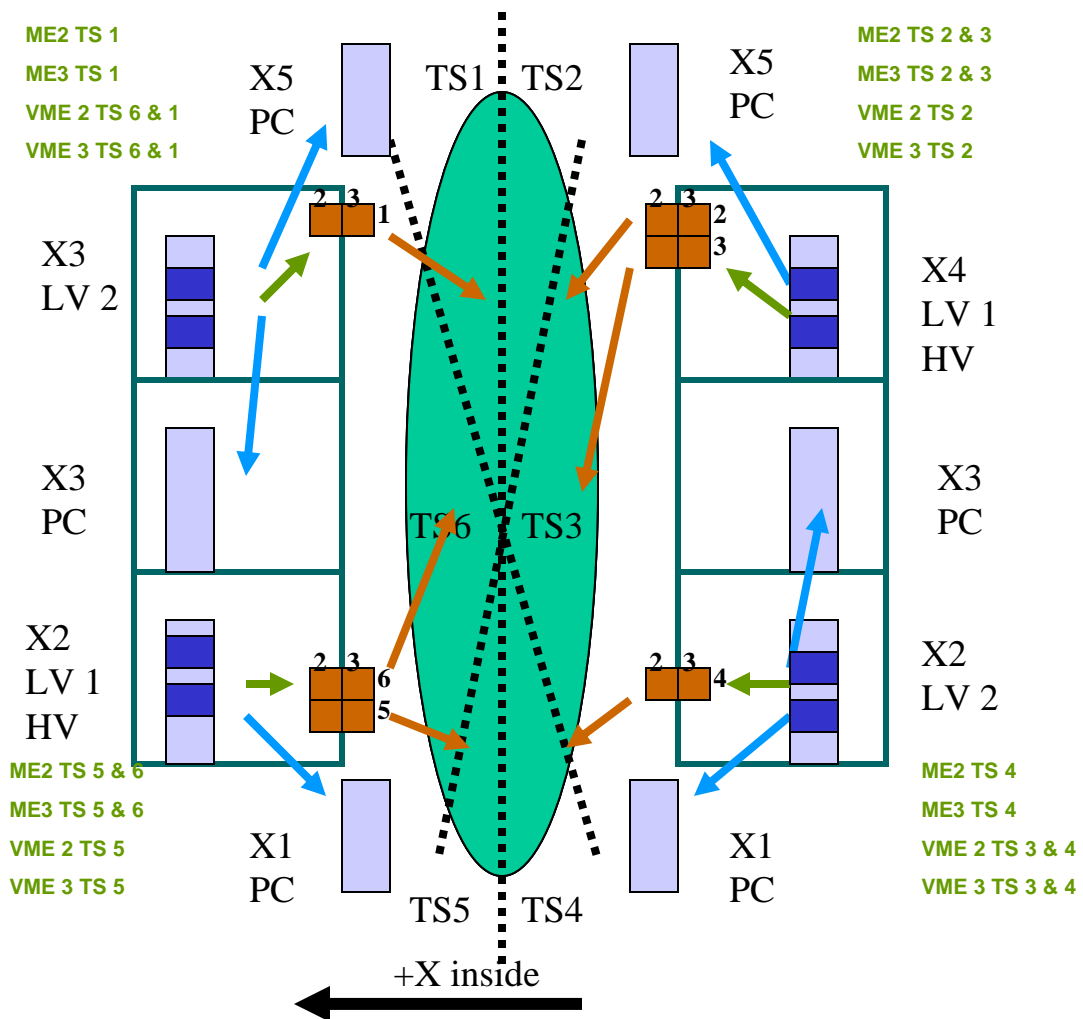



# YE+(-)3 ME LV

- Maraton in each 2 opposite corners
  - 1 power boxes per rack
- CSC LV Distribution Boxes shown in BROWN
  - 1 boxes and
- Each rack supplies
  - 2 PCs + 9 CSCs

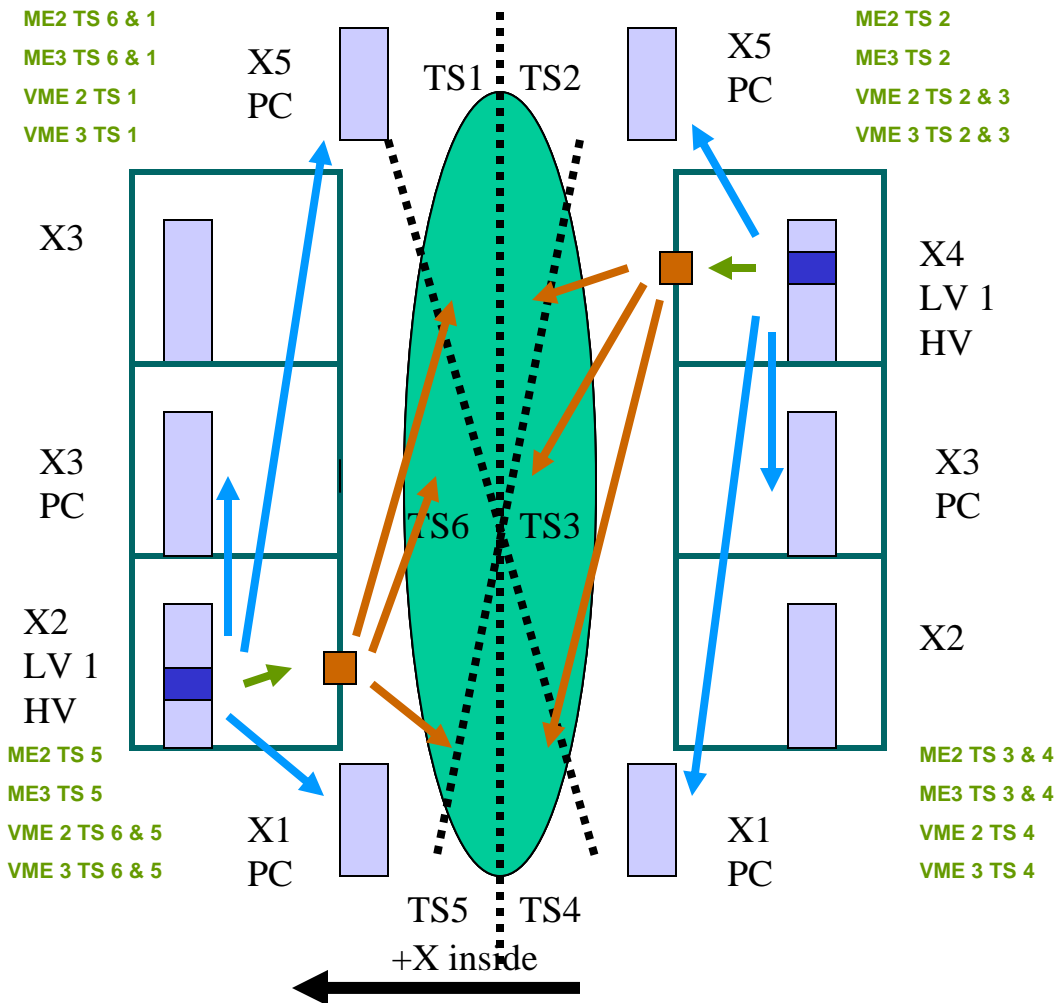



# YE1 ME LV CANBUS

- DCS CANBus for Maraton
  - From the YE1 PP
  - To the YE2 cable chain

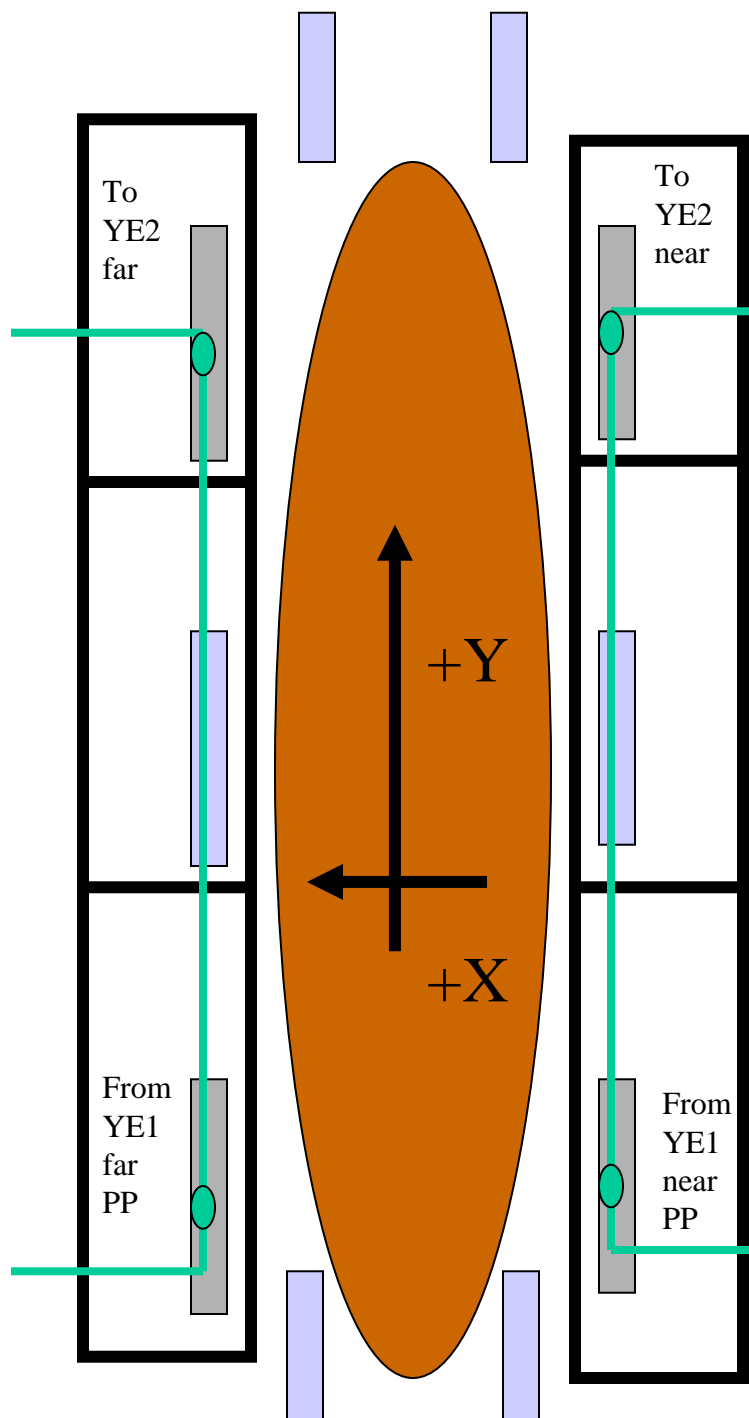



# YE2 ME LV CANBUS

- DCS CANBUS for Maraton
  - From tower to tower via the mini-cable chains

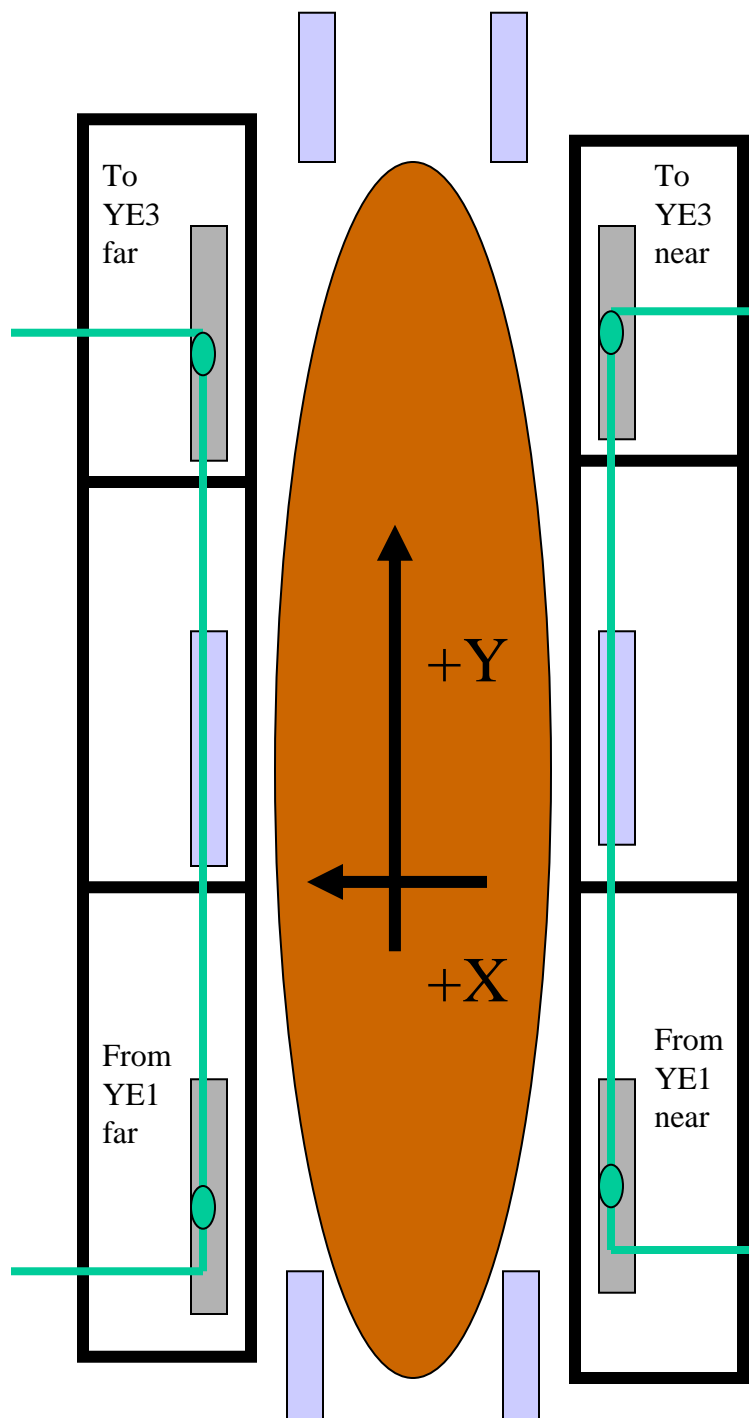



# YE3 ME LV CANBUS

- DCS

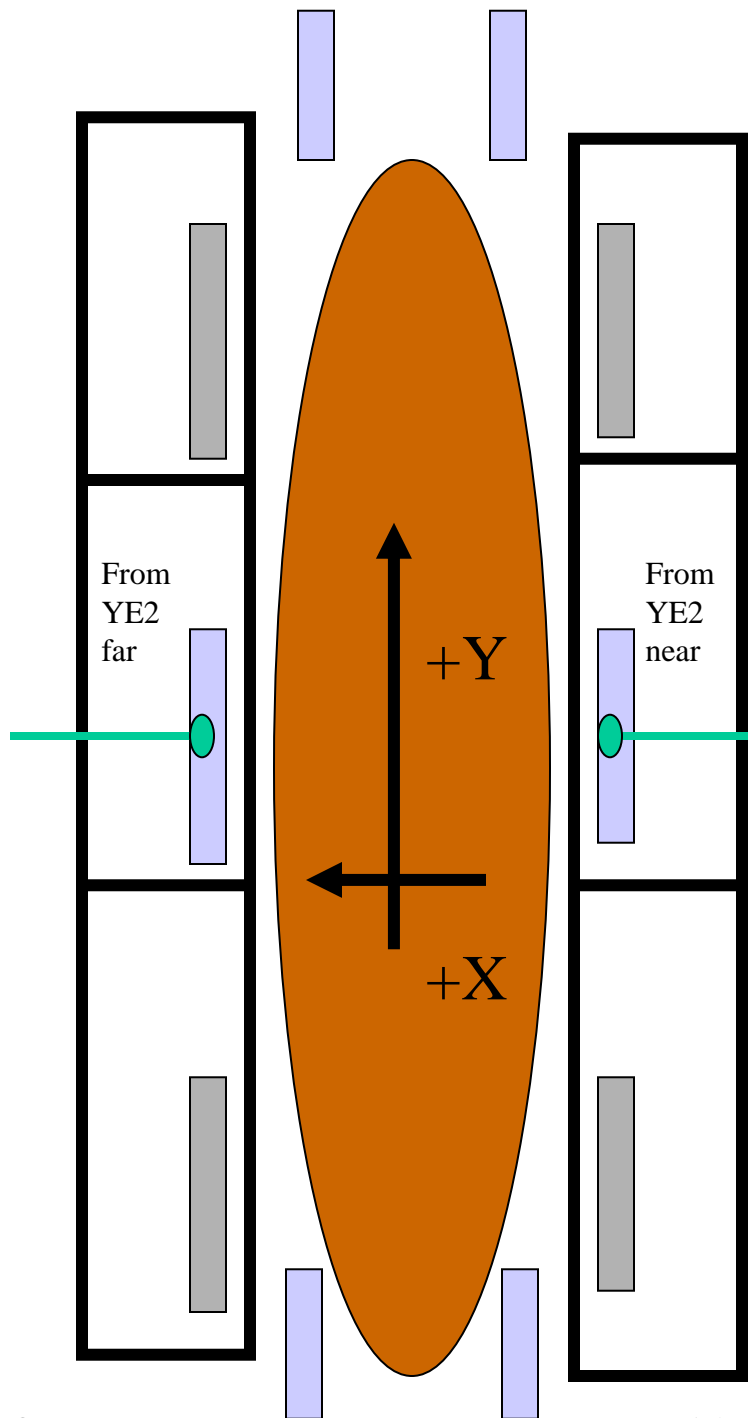



# ME LV CANBus

- CANBus for LVPS
  - From floor to YE1
  - From YE1 to YE2
  - From YE2 to YE1
  - From YE1 to YE3

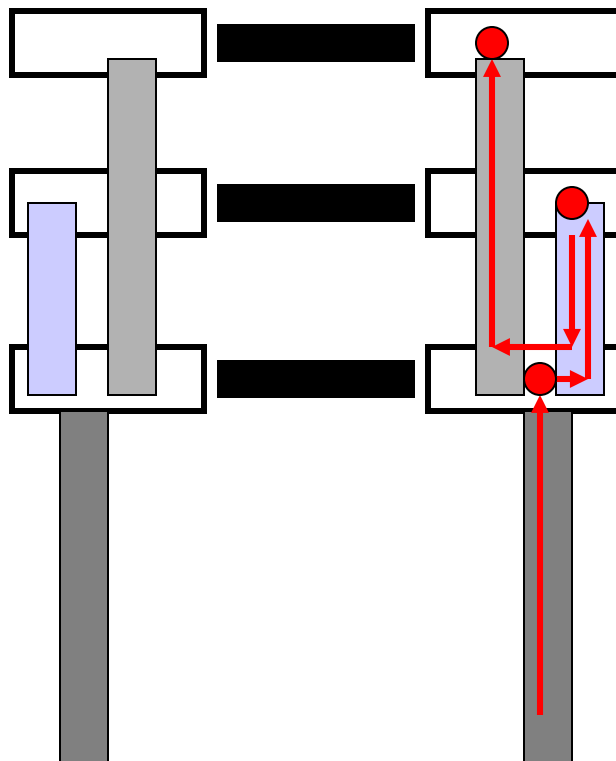





# ME LV CANBus

- CANBus for LVPS
  - 4 Zones
  - Each with 9 Maraton Power Boxes
  - 4 CANBus lines into one PCI card on DCS computer in ..

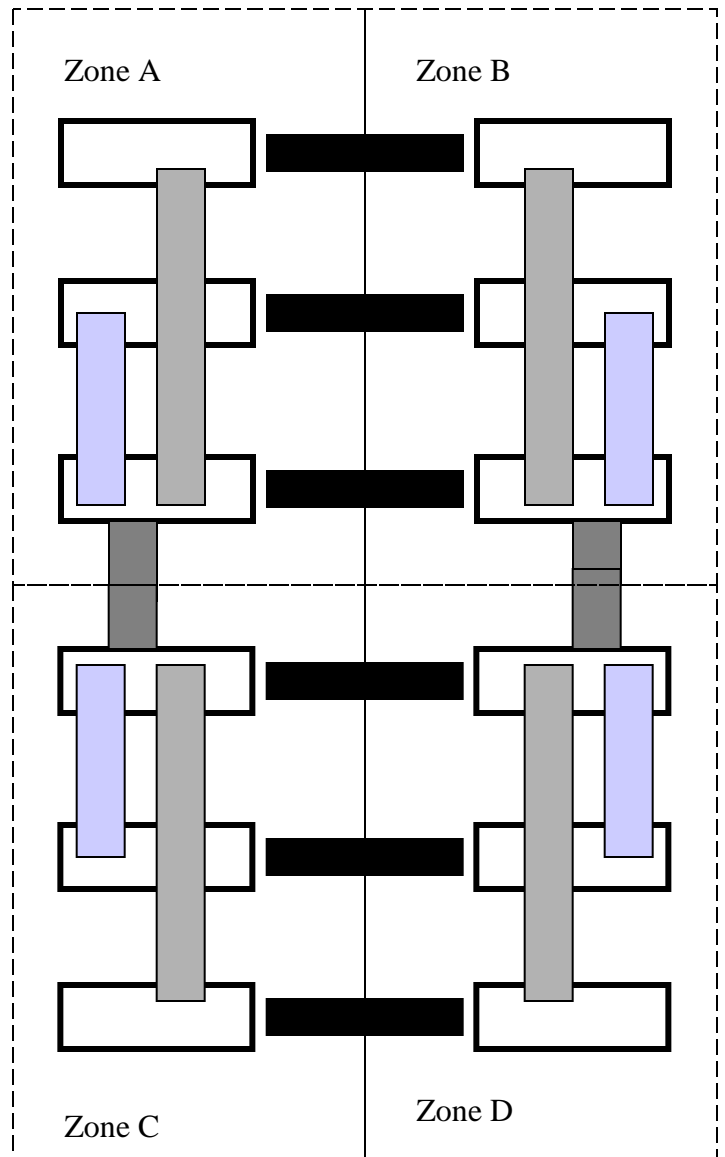



# LV YE+(-)1(2) ME LV DSS

- 3 racks on a tower are tied together in DSS
- The X3 rack is part of both zones
- Alarm condition in ANY rack in zone causes
  - 385V to both Maratons from PFC modules to trip off

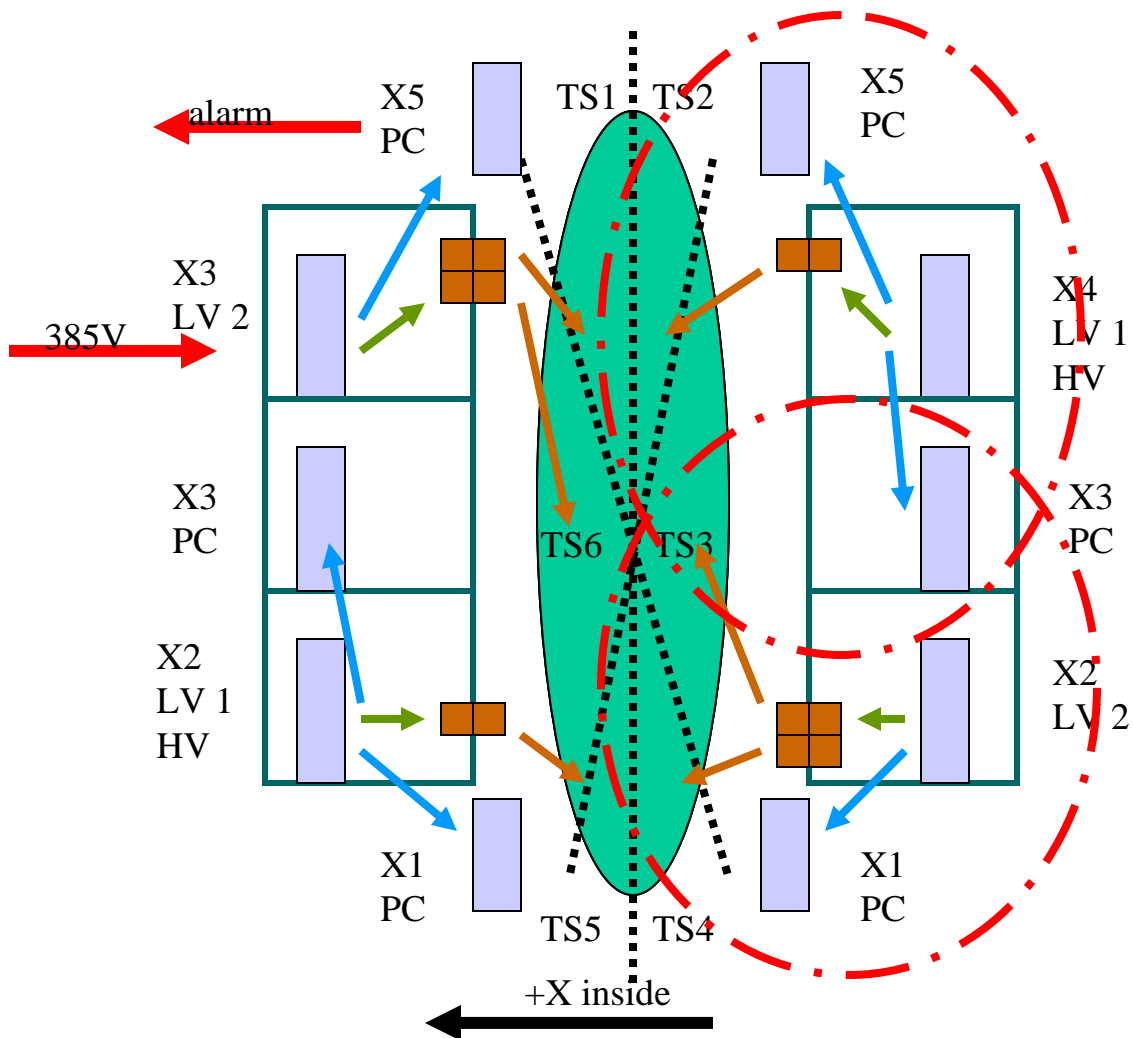



# DSS for LVPS

- 24 Zones
- Two for each tower
- Alarm in any rack in a given half-tower turns off 385V to all 3(1) Maraton Power Boxes in that tower

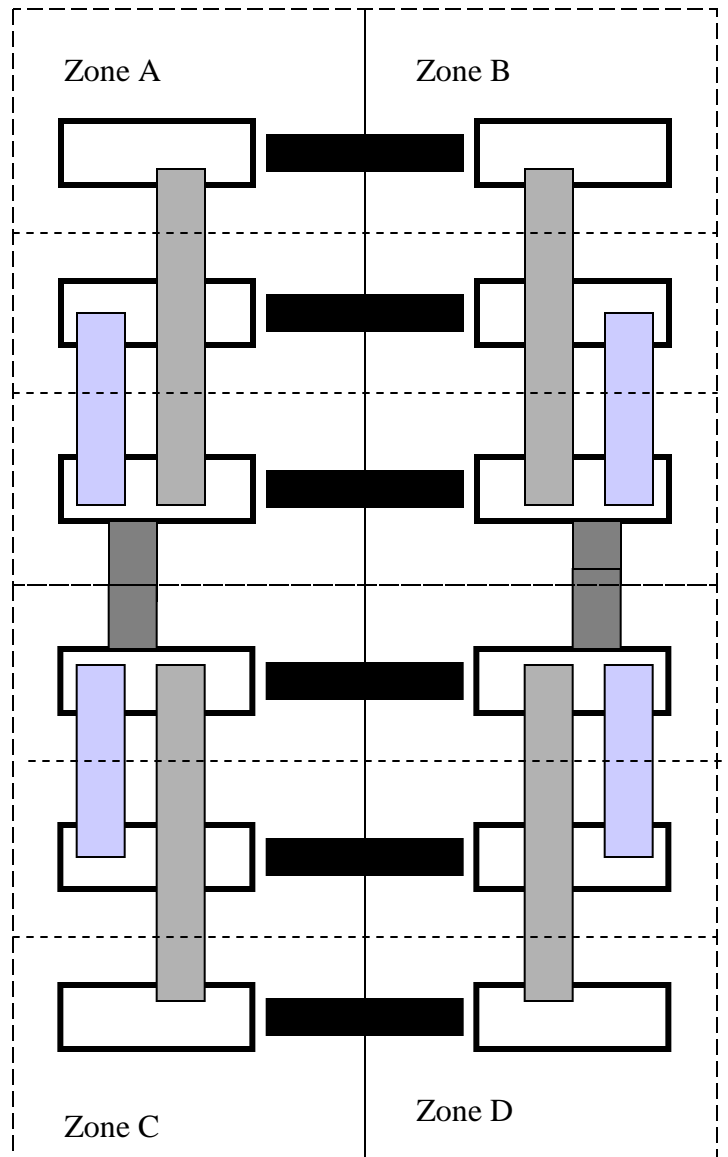



# 2 circuits for each tower on each disk



S

- Alarm in
  - X5 PC rack THEN
    - PFC for PC LV turned OFF
    - As a result
      - Maraton in X4 rack loses 385V input
      - 8V output to X5 PC also goes OFF
  - X3 PC rack THEN
    - PFC for PC LV turned OFF
    - As a result
      - Maraton in X4 rack loses 385V input
      - 8V output to X5 PC also goes OFF
  - X1 PC rack THEN
    - PFC for PC LV turned OFF
    - As a result
      - Maraton in X2 rack loses 385V input
      - 8V output to X5 PC also goes OFF



# Additional Information

- Electronics Installation Home Page
  - <http://cms-emu-slicetest.web.cern.ch/cms-emu-slicetest/904/index.htm>
- Rack Wizard

- XX



# EMU LV Overview (Peripheral Crates and CSC)

Equipment

YE-1/-2/-3, Far Side (-z, -x)

	Side	EMU
Maraton	9	36
Junction Box	13	52
Splitter Box	5	20
Breakout Box	1	4

## On-Disk Cable Length

	Side	EMU
Maraton, 380V (7x6 mm <sup>2</sup> )	~120	~ 480
Maraton, 8V (2x25 & 2x16 mm <sup>2</sup> )	~300 m	~1200 m
Maraton, CAN (4x0.5 mm <sup>2</sup> )	~150 m	~600m
CAN, PCMB, Cat5e	~150 m	~600m

## UCS-to-Detector Cables

	Side	EMU
Maraton, 380V (7x6 mm <sup>2</sup> )	5	20
Maraton, CAN (4x0.5 mm <sup>2</sup> )	1	4
CAN, PCMB (19x1.0 mm <sup>2</sup> )	1	4

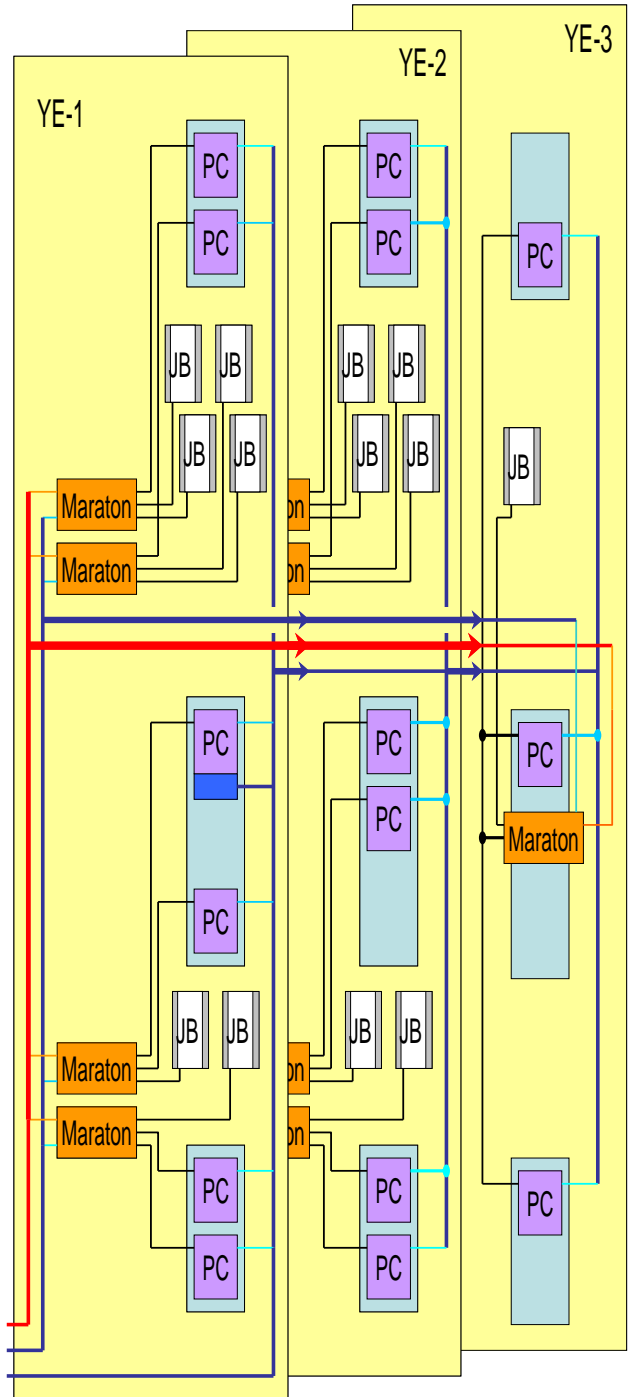

13-Jul-09

CSC On-Detector Layout -  
by Fred B.

22