

# **Modular Floating Power Supply System PL 500 / PL 6021, F8**

---

**User's Manual**

## Modular Power Supply System Series PL500 / PL6021, F8

### Floating 3U and 6 U Size

#### General Remarks

The only purpose of this manual is a description of the product. It must not be interpreted as a declaration of conformity for this product including the product and software. **W-IE-NE-R** revises this product and manual without notice. Differences of the description in manual and product are possible. **W-IE-NE-R** excludes completely any liability for loss of profits, loss of business, loss of use or data, interrupt of business, or for indirect, special incidental, or consequential damages of any kind, even if **W-IE-NE-R** has been advised of the possibility of such damages arising from any defect or error in this manual or product. Any use of the product which may influence health of human beings requires the express written permission of **W-IE-NE-R**. Products mentioned in this manual are mentioned for identification purposes only. Product names appearing in this manual may or may not be registered trademarks or copyrights of their respective companies. No part of this product, including the product and the software may be reproduced, transmitted, transcribed, stored in a retrieval system, or translated into any language in any form by any means with the express written permission of **W-IE-NE-R**.

#### Mains Voltage and Connection

The Power supplies are equipped with a "World"- mains input, which works properly from 94VAC up to 264VAC and within a frequency range of 47 to 63Hz.

Before connecting to the mains please double-check correspondence.

The mains input connection at the power supply side is done with a 3-pin Hirschmann connector (input current max. 16 A) or power terminals.

Hirschmann Pin No.	Signal	Description	Color of the Wire
Pin 1	L	Phase	black or brown
Pin 2	N	Return, Neutral	blue
Pin 3		not connected	
Earth	PE	Protective Earth	green/yellow

#### Safety

After connecting the PL5 / PL6, F8 to the mains, the mains input module is powered permanently. Filter and storage capacitors of the power factor correction module are charged with about **400VDC**. The DC-On-Signal as well as a power switch at control board (if any installed) operates as a DC on/off switch only and not as a mains breaker. **Therefore it becomes dangerous if the box cover is open. In this case a lot of components on high voltage potential get touchable!**

**Before starting any kind of work inside the power box remove the PL5 / PL6, F8 from mains and wait a couple of minutes with your activities! Discharge the primary DC Filtercapacitors by use of a well isolated 22 ohm 10W resistor.**

## Declaration of Conformity

Art. 10.2 of 89/336 and 89/392 / ECC

**W-IE-NE-R**  
Plein & Baus GmbH

---

declare under our own responsibility that the product

**PL5 / PL6, F8**

**Items: 0P00.xxxx; 0P01.xxxx; 0P04.xxxx**

to which this declaration relates, is in conformity with the following standards or normative documents :

1. EN 50 081 - 1
2. EN 61 000 3 - 2
3. EN 50 082 - 1
4. EN 60 950

Conditions:

This unit is not a final product and is foreseen for use inside a closed cabinet. The supplying of loads over long distances (>3m) needs possibly additional RF rejection hardware to get in conformity of the definition. Admitted for powering by all mains.

Name and signature of authorized person

Juergen Baus

Place and Date



**Table of contents:**

1	Device description .....	6
1.1	Commencement of operation.....	6
1.1.1	A Connection of an Personal Computer and the Power Supply PL5 / PL6, F8 .....	6
1.1.2	Control of the Power Supply PL5 / PL6, F8 via CAN-Bus (optional) .....	7
1.1.3	Control of the Power Supply PL5 / PL6, F8 without PC or Control panel (display) ..	7
1.1.4	Control of the Power Supplies PL5 / PL6, F8 with the Alphanumeric Control .....	7
1.1.5	By mains switch on the rear side (optional) .....	8
1.2	Technical Data.....	9
1.3	DC Output of different modules and floating range .....	10
1.4	Regulation.....	10
1.5	PL6021/PL500 Connection Diagram .....	12
2	Block diagram.....	13
3	Air Cooling .....	14
4	Adjustments .....	14
5	CANbus (optional) .....	15
6	Power bin.....	15
6.1	Power Supply PL5 / PL6, F8, Connection scheme.....	15
6.2	Power Supply PL5 / PL6, F8, Sense control terminals.....	16
7	Example for pinning .....	17

## 1 Device description

The PL5 / PL6, F8 can control up to 8 different floating outputs. Referring to the ground reference (VME-LOGIC-GND, pin 30 of the 37 pin D-Sub connector) the maximal floating voltage for proper regulation should not exceed +/-10V for the 2... 7V MEH outputs and also for MDL and MDH grounds. All sense- and power levels have to be in this range. For higher output voltages the floating ranges increase accordingly.

The MDL and MDH are always limited to +/-10V difference between their grounds in respect to the VME-LOGIC-GND.

### 1.1 Commencement of operation

You can put the PL5 / PL6, F8 in operation in different ways:

- 1:** By computer (through V 24 interface)
- 2:** By CANbus (optional)
- 3:** By jumpering Pin 8 with Pin 2 or 7 on the 9 DSUB connector
- 4:** By alphanumeric control panel with display (optional)  
The control board gives also the opportunity to operate special fans and watch for fan fail
- 5:** By mainswitch on the rearside (optional)

#### 1.1.1 A Connection of an Personal Computer and the Power Supply PL5 / PL6, F8

Equipment: A PC running Windows, the control program and a simple adapter.

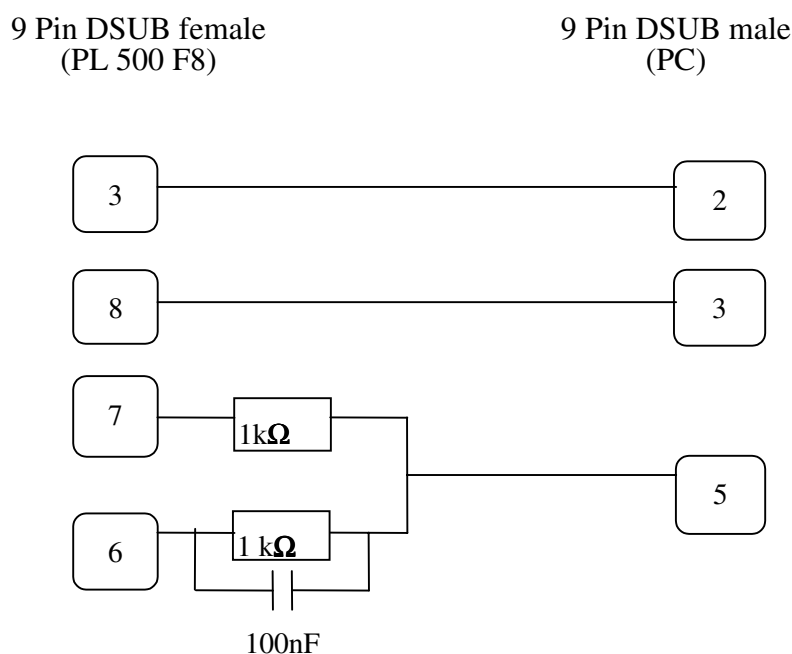

Note:

If you use Pin 3 and 8 for a serial connection to a computer, you can't use this pins for the „Remote

On“ and „Status Out“ functions and you can connect neither the power supply to an alphanumeric control panel (see below 4) nor operate with remote on / off (see below 3).

### 1.1.2 Control of the Power Supply PL5 / PL6, F8 via CAN-Bus (optional)

The CAN Bus Signals are provided on the 9 Pin DSUB:

CAN\_H: Pin 5

CAN\_L: Pin 9

CAN\_GND: Pin 4

The software protocol is described in a separate document (Part No \*00183)

CANbus is an independent port. It may used also in combination with the operation modes of 1, 3, 4, and 5

### 1.1.3 Control of the Power Supply PL5 / PL6, F8 without PC or Control panel (display)

There is a remote on/off input and a status output function:

Remote On: 9 Pin DSUB: Close a “make” contact or switch between Pin 8 (Serial Data In) and Pin 2 or 7.

Status Output: 9 Pin DSUB: Connect a LED between Pin 3 (Serial Data Out,+) and Pin 1 or 6.

### 1.1.4 Control of the Power Supplies PL5 / PL6, F8 with the Alphanumeric Control

Many power supply parameters may be changed via the alphanumeric control of the connected fan tray.

The general procedure is:

- Switch the POWER and the MODE switch up simultaneous for 5 seconds. The display shows „Config: Wait...“ and „Config: Ready !“. Then release both switches.
- If a sub-menu exists, you may now select the sub-menu item (MODE switch up/down). If no sub-menu exists, you may change the parameter value (MODE switch up/down)
- To change a parameter of a sub-menu, select it (POWER switch up). The selected parameter is flashing now.
- You may alter the parameter now (MODE switch up/down)
- After finishing the parameter programming, leave the submenu or configuration menu (POWER switch down).

Mode	associated parameter submenu	Description
Any Voltage (e.g. +5V or U0)	Ilim	Output Current limit
	Uadj	Output voltage fine adjustment. The same function as the switches in the power supply
	Unom	Output voltage coarse adjustment.
	Imax	Monitoring: Maximum current for good status.
	Umin	Monitoring: Minimum voltage for good status.
	Umax:	Monitoring: Maximum voltage for good status.
Power	Auto Power On No Auto Power On	Automatic switch on of the power supply after come back of the mains
	Switch Off Normal Switch Off Delay	Delayed switch off: You have to push the POWER switch down for 5 seconds until the power supply switches off
OPTIONALLY:		
Fans	Watching x Fans	Display of the number of monitored fans
Fan Temp	Temp Display: °C Temp Display: °F	Select the temperature unit: Celsius or Fahrenheit
Bin Temp x (up to 8 sensors)	PsOff	If the temperature of sensor x is above this limit, the power supply will switch off.
	FanUp	If the temperature of sensor x is above this limit, the fan tray fan speed will increase to full speed.

### 1.1.5 By mains switch on the rear side (optional)

Use “mains switch” at the rear side to start the PL5 / PL6, F8.

Also this optional rocker switch acts as a DC on / off switch and doesn't disconnect mains from the unit



## 1.2 Technical Data

- Up to eight independent potential free outputs with >5 kW at 230 VAC
- Fully controlled, programmable trip levels
- Voltage ramp up within (50ms fix) monotony and synchrony,  
Ramp down as fast trip. Output capacitors discharging by crow bar
- Extremely low noise and low ripple
- CE conform EN 50081/82 part 1
- Safety in accordance to EN 60950
- Sinusoidal mains current to EN 61000-3-2

The **PL 500** has been constructed to provide external load channels with high power consumption over long distances.

Voltages, currents, temperatures and output power are controlled by internal processor and illegal modes as well as failure will be detected.

A fast sense circuit and a delayed remote-sense compensation guarantees continuously and stable operation, even with long inductive wiring to the loads.

The difference to the **PL 6021** is the lack of the remote sense slow regulation. Therefore UEP 6021 is foreseen for either powering loads in sensed mode over a short distance or unsensed over all distances.

A control board with display for data and diagnostic is optionally available for installation near to the PL5 / PL6, F8, preferably in the 19" power bin. Connection has to be achieved by use of the V24 loop.

Optional programming and monitoring can be done by CANbus interface.

### Module cage formats

6 U box: max. 10 modules, up to 5.6kW output power

Connections / plugs: 10 pins 250A, 8 pins 150A

Size (WxHxD): 434 mm x 260 mm x 255mm

3 U box: max. 5 modules, up to 2kW output power

Connection / plugs: 10 pins 250A, 8 pins 150A

Size (WxHxD): 434mm x 132mm x 255mm

3U box with alternative C or H input, 6U box suitable for all inputs. Plugs until 16A input current, above 16A terminals with 2m power cord, fixed . Available output power depends on input voltage and is listed above for the full mains voltage range.

**Mains input CE****H/K Sinusoidal:** EN 60555, IEC 555 pow. fact.0.95(230VAC), 92..264 VAC, 16/32A**Inrush current:** limited by softstart circuit below nominal input current (cold unit)**Isolation CE****Inp.-outp.:** acc. to EN 60950, ISO 380, VDE 0805, UL 1950, C22.2.950**Fuse:** extern 16A or 32A according to typing sticker (only special ones with internal slow blow fuses)**DC Output** power with different mains inputs (16A/32A), calculated with typical efficiency of 72%**115VAC / 1.325W**      **230VAC / 2.650W**      3U power box, 16A input**115VAC / 2.650W**      **230VAC / 5.300W**      6U power box, 32A input**1.3 DC Output of different modules and floating range**

The listed "floating range" refers always to the VME-LOGIC-GND of the 37 pin Sub D connector

min. to max. range	floating range	max. output	(with C, E, H, K mains input)
2 - 7,0V	+/- 10V	115A / 550W	type MEH
4 - 10,0V	+/- 15V	85A / 650W	type MEH
7 - 16V	+/- 20V	46A / 550W	type MEH
12 - 30V	+/- 30V	23A / 550W	type MEH
30 - 60V	+/- 70V	13,5A / 650W	type MEH

**Note:** The max. floating range of MEH modules is to understand that all output levels have to be inside the voltage range. Also if outputs should operate in +/- or other cascading condition.

2 - 7.0V	+/- 10V	(±)20A/140W(280W)	type MDH
7 - 24V	+/- 10V	(±)11.5A/140W.(280W)	type MDL
7 - 30V	+/- 10V	(±) 7.4A/180W.(360W)	type MDL

**Note:** The max. floating range of MDL and MDH modules concerns only the difference between the "grounds" of the module and the VME-LOGIC-GND. The "ground" pins of the double module are marked with a \* on the type plate. They are not connected together and passed to the output connector pins separate.**1.4 Regulation (PL 6021)**

Static:

MEH 550W/650W      &lt;25mV      (± 100% load, ± full mains range)

MDH 20A:      &lt;0.1%      (± 100% load, ± full mains range)

MDL (11.5A/7.4A)      &lt;0.1%      (± 100% load, ± full mains range)

Dynamic:

MEH, MDH:      &lt; 100mV      (± 25% load)

MDL (11.5A/7.4A):      &lt;0,7%      (± 25% load)

Recovery time $\pm 25\%$ load: (Power Supply terminals)	within $\pm 1\%$	within $\pm 0,1\%$
Modules 550W	0,2ms	0,5ms
Modules 650W	0,5ms	1,0ms
MDL (11.5A/7.4A):	0,0ms	1,0ms

**Sense compensation range:**

up to maximum module voltage range

Noise and ripple, 50cm wire:	$< 10\text{mV}_{\text{pp}}$	(0-20MHz)	$3\text{mV}_{\text{rms}}$	(0-2MHz)
10m wire:	$< 3\text{mV}_{\text{pp}}$		(0-300MHz)	
Conditions, at load site:	Parallel (X) $\geq 330\mu\text{F}$ and $\geq 1\mu\text{F}$ ceramic, 100nF HF- conducting to case (Y)			

**Electromagnetic Compatibility**

Emission :	<b>CE</b>	EN 50081-1,
Immunity:	<b>CE</b>	EN 50082-1 or 2
Operation temperature:	0...50°C without derating, storage: -30°C till 85°C	
Temp.- Coefficient:	$< 0.2\% / 10\text{K}$	
Stability (Condition const.):	$< 5\text{mV}$ or $0.1\%$ within 24 h, $< 25\text{mV}$ or $0.5\%$ within 6 month	
Current limiting:	100% of nominal values, programmable to lower values via interface or display tableau.	
Voltage rise:	monotony, synchrony, within 50 ms (factory settings),	
Voltage off:	discharge of output capacitors after DC off.	
Over voltage protection:	Factory settings to 125% of nominal values	
Status control:	within 5ms if $> 2\%$ deviation from nominal or programmed values, after overload, overheat, overvoltage, undervoltage	
Interlock input (option):	High level or open: All outputs DC off	
AC-fail and Sys-Reset:	Generation according to VME Specification, optional	
Temperatur limits:	110°C heat sink, 70°C ambient intern	
M T B F at 40° ambient:	$> 65.000\text{h}$ (blower), electronics $> 100.000\text{h}$	

## 1.5 PL6021/PL500 Connection Diagram

## POWER CONNECTOR

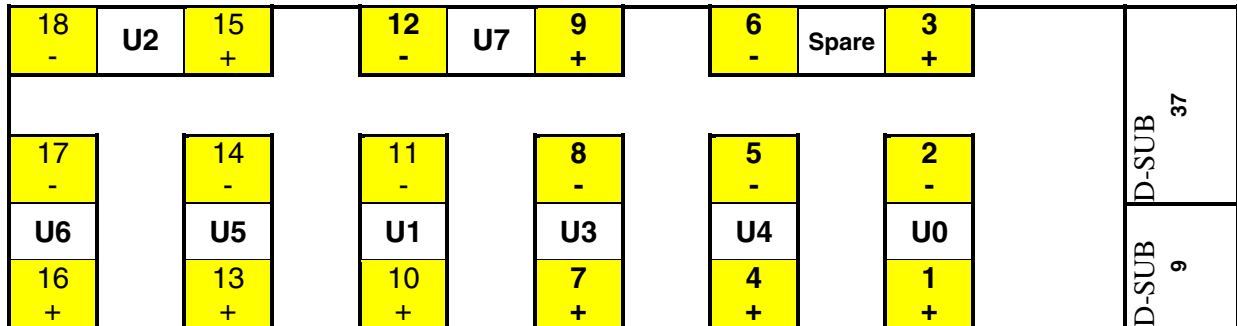

Pin 10,11,13...18: 6mm, 120A max.

Pin 1...9+12: 8mm, 240A max.

Polarity: + positive - negativ

U0 to U7 = standard pinning only!

SENSE/SIGNAL CONNECTOR D-SUB 37			
		19	TEMP RETURN
37	TEMP 0	18	TEMP 1
36	TEMP 2	17	TEMP 3
35	TEMP 4	16	TEMP 5
34	TEMP 6	15	TEMP 7
33	BIN EEPROM: IIC SDA	14	BIN EEPROM: IIC SCL
32	BIN EEPROM:+5V	13	VME LOGIC: SYSRESET
31	BIN EEPROM: GND	12	VME LOGIC: ACFAIL
30	VME LOGIC GND	11	VME LOGIC: SYSFAIL
29	U0 SENSE -	10	U0 SENSE + (VME: +5V)
28	VW SENSE (reserved)	9	VW SENSE (reserved)
27	VX SENSE (reserved)	8	VX SENSE (reserved)
26	U4 SENSE +	7	U4 SENSE -
25	U7 SENSE +	6	U7 SENSE -
24	U2 SENSE -	5	U2 SENSE + (VME: 48V)
23	U6 SENSE +	4	U6 SENSE -
22	U1 SENSE -	3	U1 SENSE + (VME: +12V)
21	U5 SENSE +	2	U5 SENSE - (VME: -12V)
20	U3 SENSE -	1	U3 SENSE + (VME: +3.3V)
FAN/CONTROL CONNECTOR D-SUB 9			
		5	CAN_H
9	CAN_L	4	CAN GND
8	RXD	3	TXD
7	+15V (for fan only)	2	+15V (for fan only)
6	-15V (for fan only)	1	-15V (for fan only)

## 2 Block diagram

90 (94) ... 264 VAC input

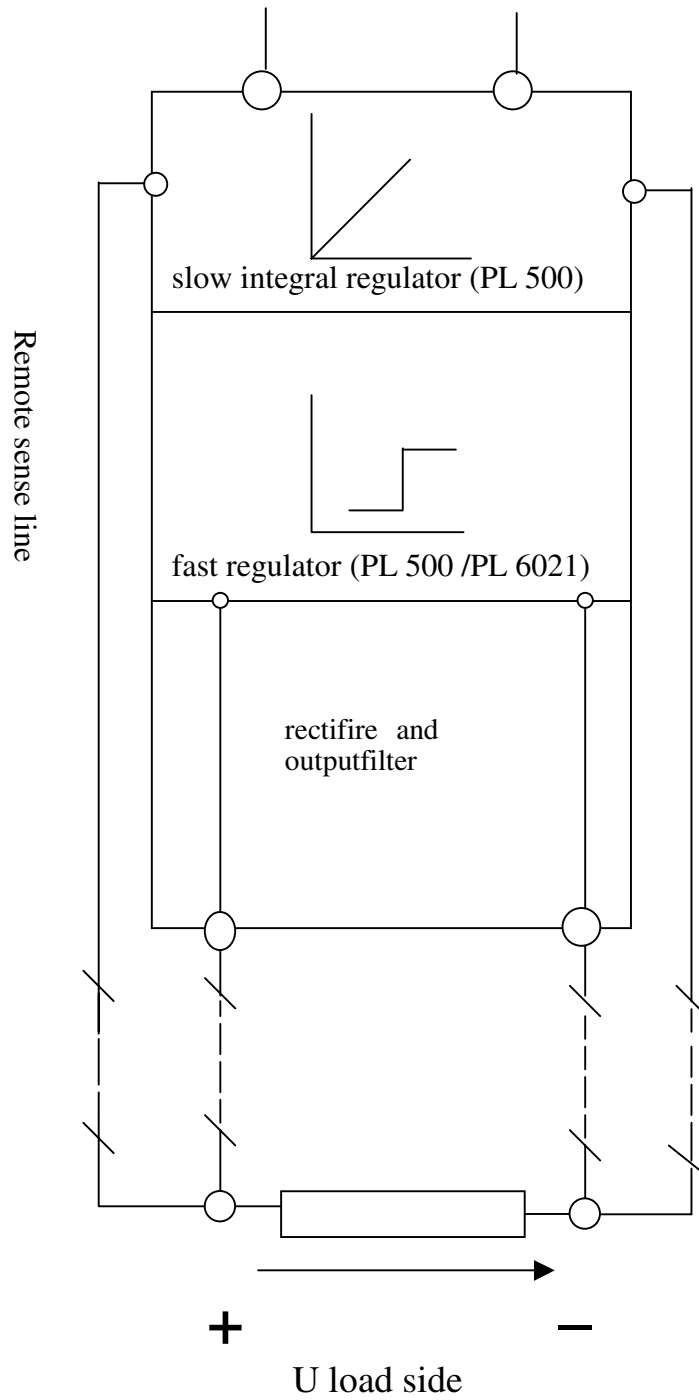

### 3 Air Cooling

In order to produce a proper working condition it is very important, that the cooling air can pass the device without any handicap. The air intake comes from the bottom and will leave the equipment from its top, so it must be assured that the airflow doesn't hit any hindrance.

### 4 Adjustments

All output voltages can be adjusted manually via the two rotary switches situated on the power supply top.

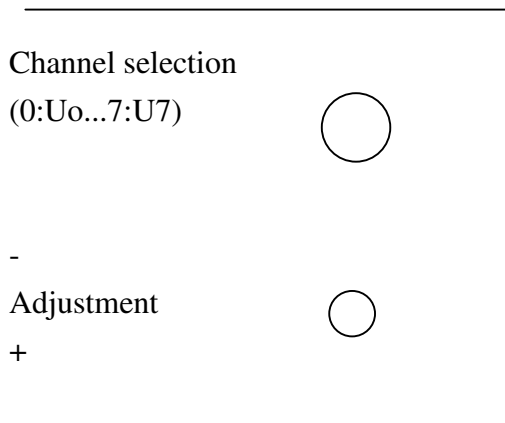

Mode Selection	Function
0-7	Adjust Voltage of U0-U7
A	CAN Address (low, Bit 0-3)
B	CAN Address (high, Bit 4-6)
C	CAN General Call Address (low, Bit 0-3)
D	CAN General Call Address (high, Bit 4-6)
E	CAN Transmission Speed Index

## 5 CANbus (optional)

### CAN Transmission Speed Index

Index	Max. Distance	Bit Rate	Type
0	10 m	1.6 Mbit/s	high- speed  (needs termination)
1	40 m	1.0 Mbit/s	
2	130 m	500 kbit/s	
3	270 m	250 kbit/s	
4	530 m	125 kbit/s	
5	620 m	100 kbit/s	low-speed
6	1.300m	50 kbit/s	
7	3.300 m	20 kbit/s	
8	6.700 m	10 kbit/s	
9	10.000 m	5 kbit/s	

For software protocol see separate manual No. \*00183

## 6 Power bin

A suitable range of 19" racks equipped with PL 5 / PL 6, F8 counter part connectors and guiding bars for bearing the power boxes is available. Cooling air intake can be from front or bottom side in standard power bins. Also when a control board with display will installed either bottom or front intake may select.  
For the power plugs 1 to 9 and 12 are M8 studs and for 10, 11 and 13 to 18 are M6 studs foreseen.

Sense- and control connectors (9 pin and 37 pin) are wired to a terminal board

### 6.1 Power Supply PL5 / PL6, F8, Connection scheme

Rear view to power bin connectors / terminal studs

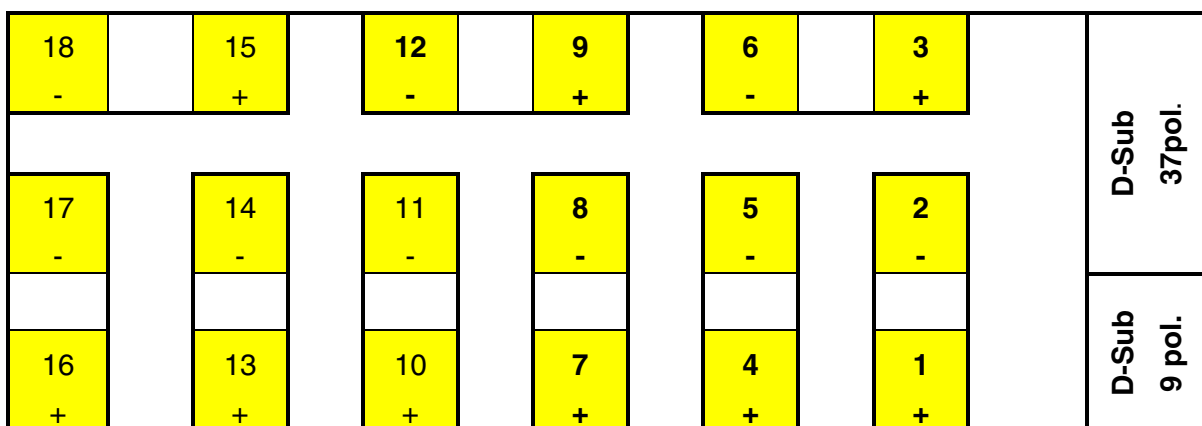

**6.2 Power Supply PL5 / PL6, F8, Sense control terminals<sup>1</sup>**

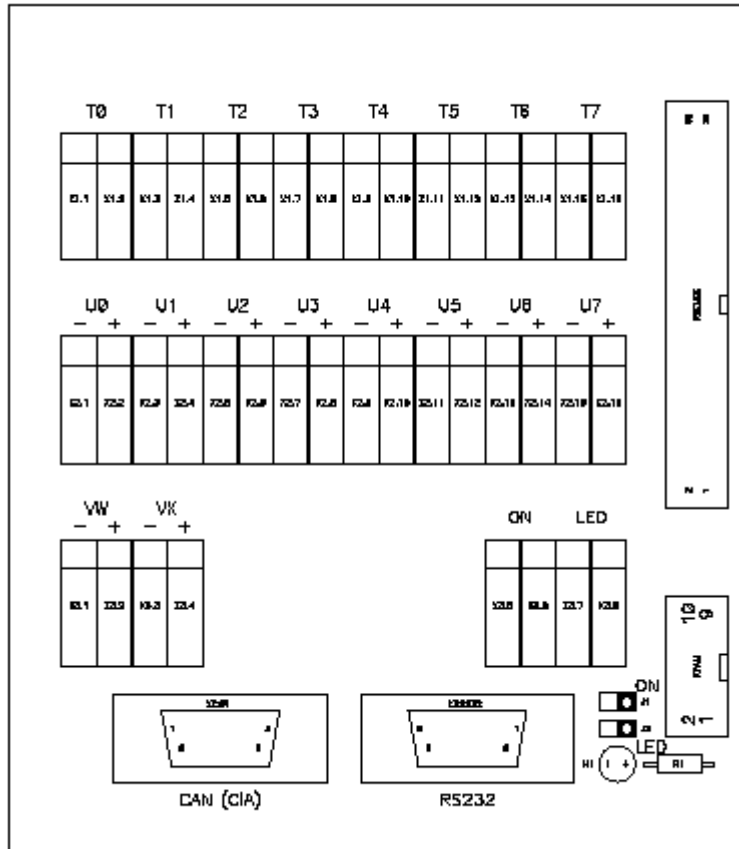

T0-T7            Temperature Sensor terminals (optional)

U0 ... U7:        Sense lines

ON                Connecting the two pins with the jumper or an external switch will switch the power supply on. (Then no V24 connection is possible).

LED                Status LED. Insert the LED if you wish to use the LED. You may connect an external LED to the terminals (left: +, right:-). In that case the pcb wire which short the LED terminals must be cut. . (Then no V24 connection is possible).

On this board, the U0-SENSE is connected to VME-LOGIC-GND.

<sup>1</sup> Only implemented in power bins produced after June 2000.



## 7 Example for pinning

Due to the long range of different configurations there are no pin out fixed.

The real pin assignment is given by the type sticker on rear side of the power box PL 500 / PL 6021.

It is showing voltages and currents with respect to the output number 0... 7 with the corresponding pin number and polarity.

Each output has a pair of contacts (+/-, floating). The "ground"-pins of MDL/MDH double modules (which must be used to calculate the floating range) are marked with a \*.

**115VAC / 1.325W**

**230VAC / 2.650W**

3U power box, 16A input

<b>W - Ie - Ne - R</b> <b>Plein &amp; Baus GmbH</b>			
Typ / type	PL 6021		
Teile Nr. / part no.	0P00.0142		
Serien Nr. / ser.no.	2099015		
Eingang / input	90- 265V AC/ 47- 63Hz max. 16A		
Sicherung / fuse	external 16AT		
Leistung / power	Pout (90VAC): 1080W		
Ausgang / output	Pout (>209VAC): 2250W		
U0	3,7V/ 115A;	1+ / 2 -	U1 6V/ 90A; 10 + / 11 -
U2			U3 4,3V/ 115A; 7 + / 8 -
U4	3,7V/ 115A;	4 + / 5 -	U5 6V/ 90A; 13 + / 14 -
U6			U7
Germany (0)2174/678-0 Fax (0)2174/678-55		URL: <a href="http://www.wiener-d.com">http://www.wiener-d.com</a>	